

# The BMW 3 Series Coupés



## Contents

### Views

Pages 4-11

### Drive technology

Pages 12-17

### Interior

Pages 18-19

### Personal Line

Pages 20-21

### M3 reference

Pages 22-23

### Special equipment

Page 24

### Service and finance

Page 25

### Tables:

#### Standard equipment

Pages 26-27

#### Specifications

Page 28

#### Special equipment

Page 29

#### Personal Line

Pages 30-31



**Performance** the way we define it is a result of enthusiasm and the urge to take a new, innovative approach. This is precisely the philosophy represented most convincingly by the BMW 3 Series Coupé. A car providing an all-new rendition of agility and handling far beyond the usual dimensions of speed alone. With styling to meet the greatest demands in exclusive, aesthetic design as well as highly efficient, unrestricted function. With suspension providing the foundation for a thrilling experience on the road. With the most advanced and sophisticated power units, the 3 Series coupé featuring agile 1.6- and 1.9-litre four-cylinder power units as well as smooth and refined six-cylinders in the 328i and the 323i model. At the top of the range, the 2.8-litre produces impressive power and performance, just right for driving in superior style in a car offering sheer driving pleasure at its very best.

The dynamic looks of the BMW 3 Series coupé are the result of a successful blend of technology and passion. In its design, the coupé offers the highest level of streamlining and functional value. In the same way it is a timeless expression of sheer driving pleasure today and in the future.



The new 328i – an outstanding combination of exceptional elegance and

thrilling performance everywhere you go.



The dynamic styling and clear lines of the BMW 3 Series coupé come together to provide unique flair emanating both

exclusive aesthetic style and unrestricted functional value.

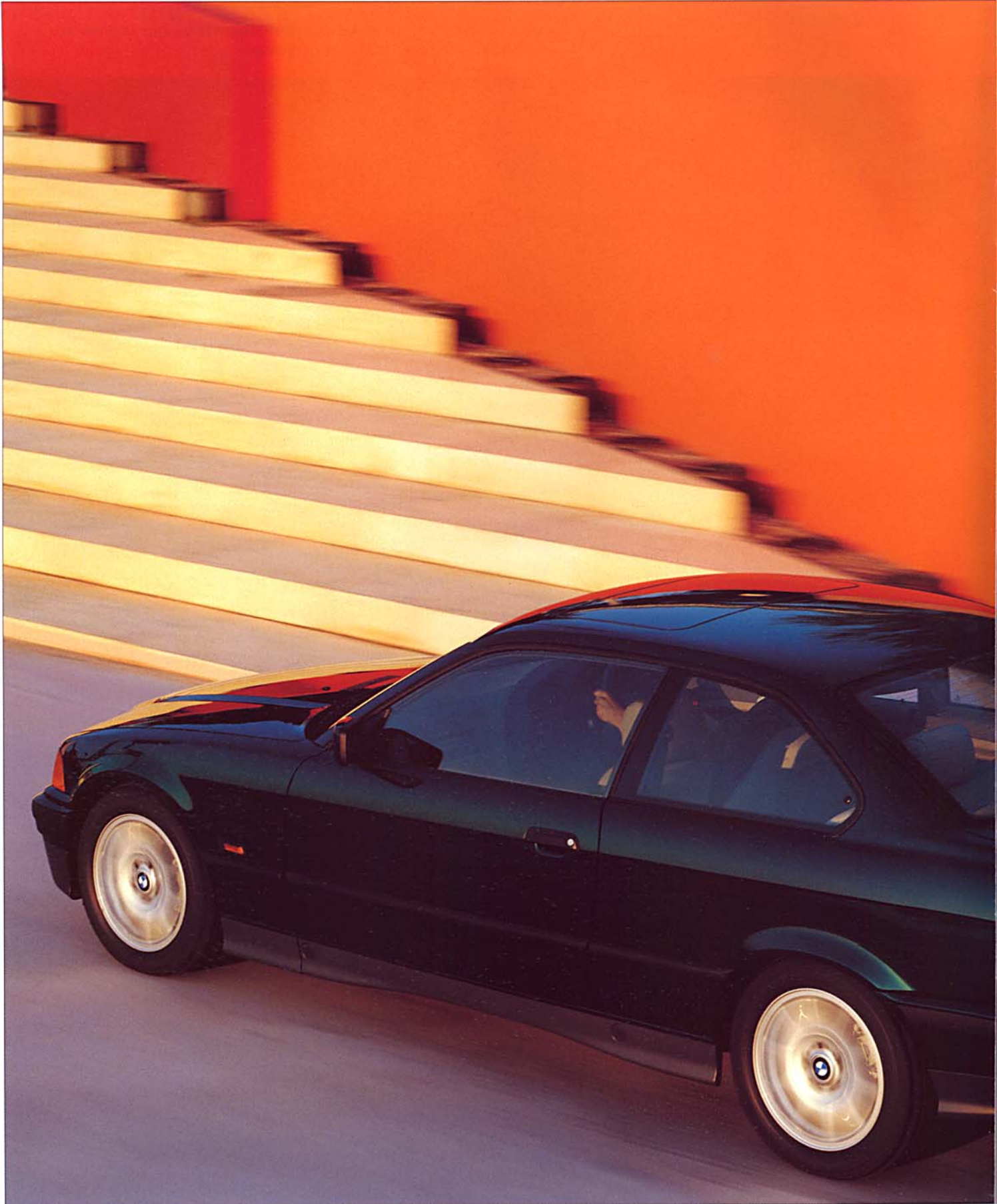

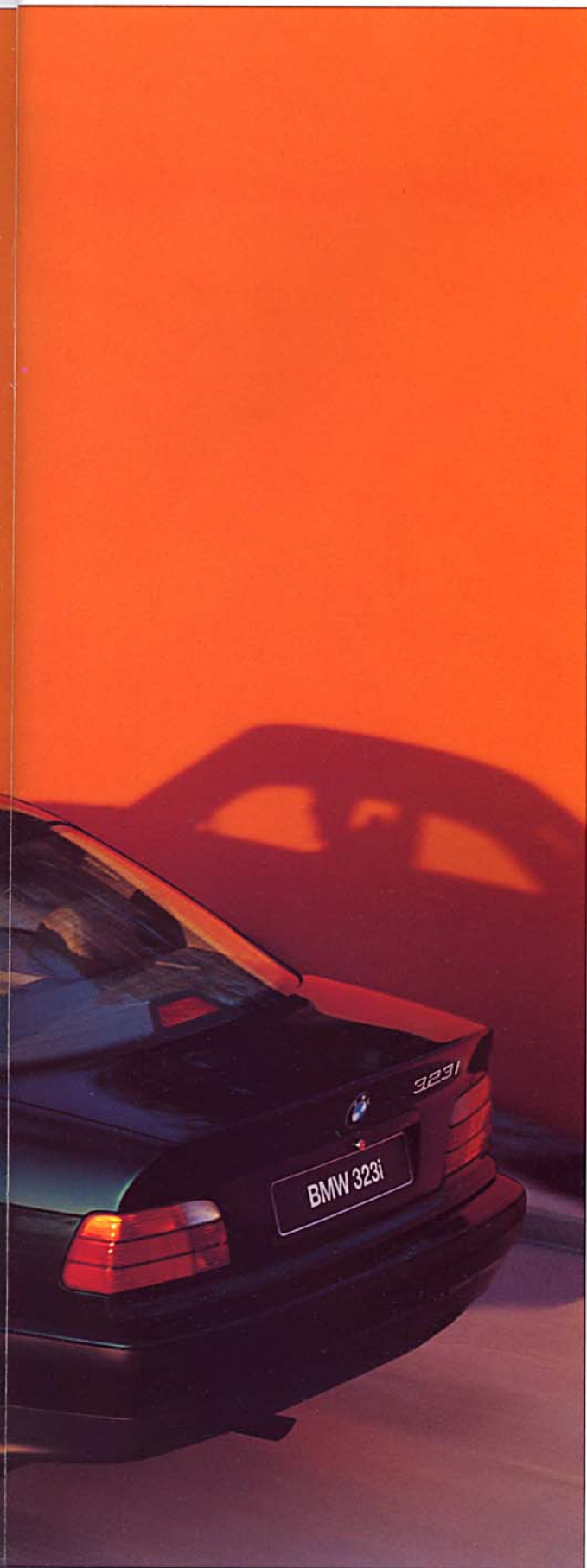

Unique in five versions: The right size for today's world plus elegant styling – these are the characteristics of all BMW 3 Series coupés.



A perfect blend of form and function is ensured, for example, by the frameless windows moving down by a few millimetres when the doors are opened and then moving up again when the doors are closed in the interest of optimum acoustic control.



Flowing, graceful lines give the BMW coupé a standard of elegance simply thrilling from every angle.

**The foundation for agility** is provided by the elaborately designed suspension. Excellent tuning of all components and well-balanced weight distribution, in conjunction with the powerful, free-revving engines, ensure driving characteristics which set new standards for cars of this class.

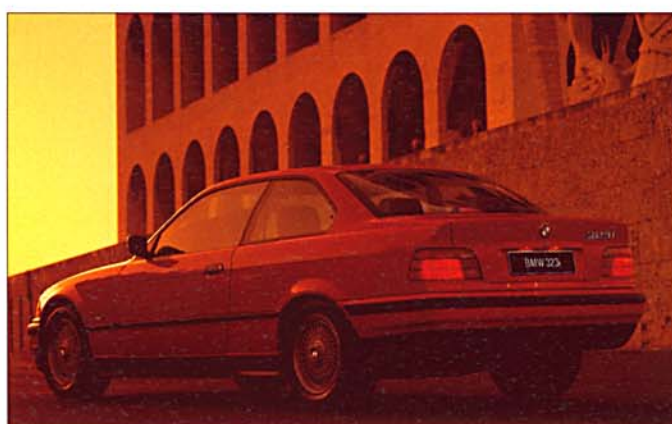

The long wheel-base and patented rear axle are just two of the many features ensuring outstanding driving characteristics, dynamism and safety on the road.



Whether on winding country roads or on the motorway, the 3 Series coupé offers

absolutely thrilling driving behaviour and superior comfort.



The 328i Sport has been developed by BMW M GmbH – with its full colour aerodynamic bodykit, specially tuned suspension system, 17 inch alloy wheels and sports seats. The sporting character of the 3 Series Coupé is further enhanced.

**Driving with enthusiasm,** as we see it, means motoring in relaxed style. For example thanks to the comfortable interior, and in particular thanks to the ergonomically designed cockpit relieving of virtually every chore. Just one look gives you the information you need, one movement of your hand gets you to the controls.



Where sheer driving pleasure is created: Exemplary ergonomics, top-quality materials, an excellent finish, and

superior noise insulation provide that unique BMW ambience.



The new generation of BMW six-cylinders is the result of advanced technology combined with an advanced philosophy. We have increased the car's torque and flexibility, not its output. We have reduced fuel consumption, not the refinement and agility you enjoy at the wheel. So in brief, we give new drive to your joy of motoring.

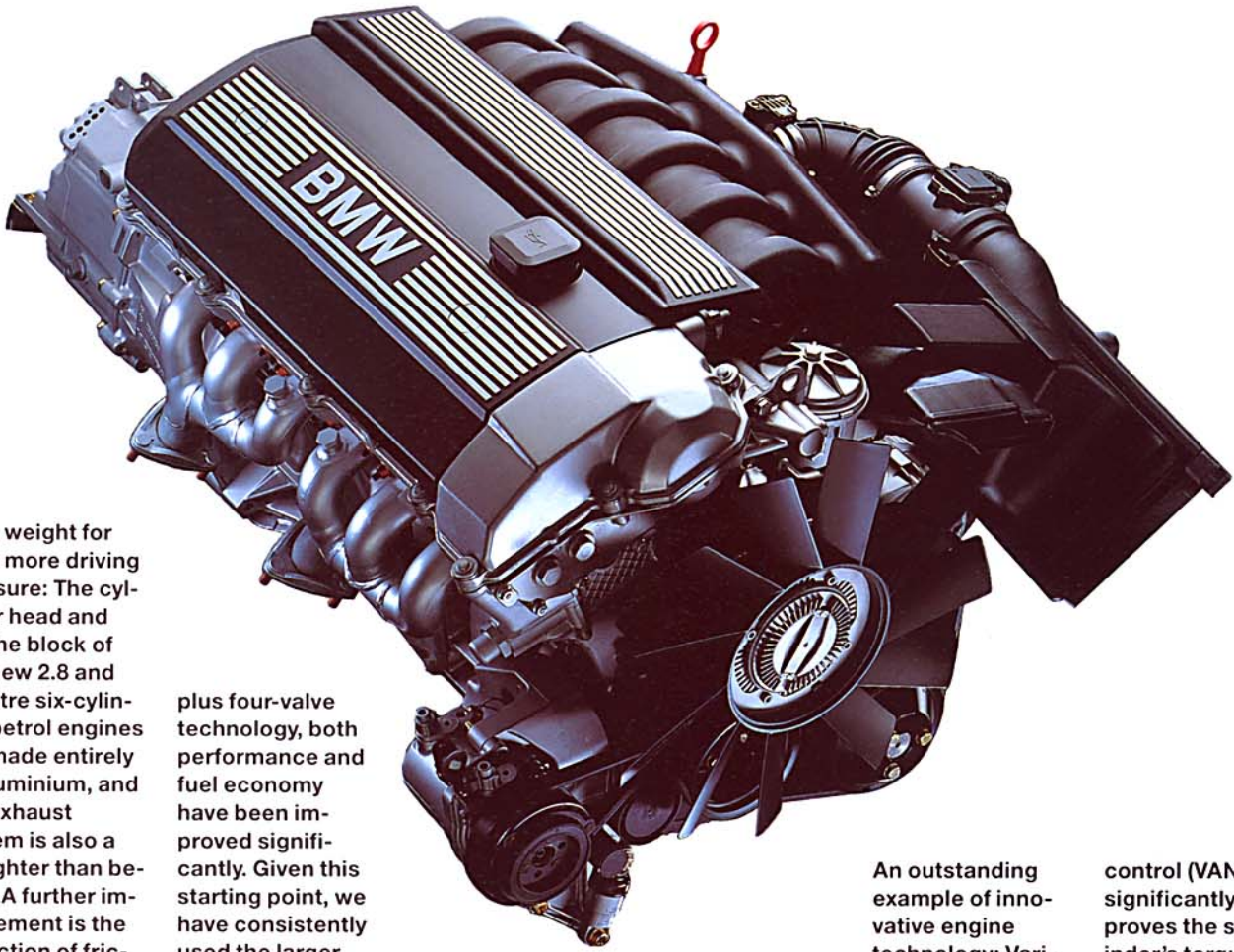

Less weight for even more driving pleasure: The cylinder head and engine block of the new 2.8 and 2.5-litre six-cylinder petrol engines are made entirely of aluminium, and the exhaust system is also a lot lighter than before. A further improvement is the reduction of friction within the engine itself, and in conjunction with the most advanced Digital Motor Electronics

plus four-valve technology, both performance and fuel economy have been improved significantly. Given this starting point, we have consistently used the larger capacity of the 2.8-litre power unit to generate extra torque from the lowest engine speeds.

An outstanding example of innovative engine technology: Variable camshaft

control (VANOS) significantly improves the six-cylinder's torque curve, power developing even more smoothly and flexibly throughout the engine's entire speed range.

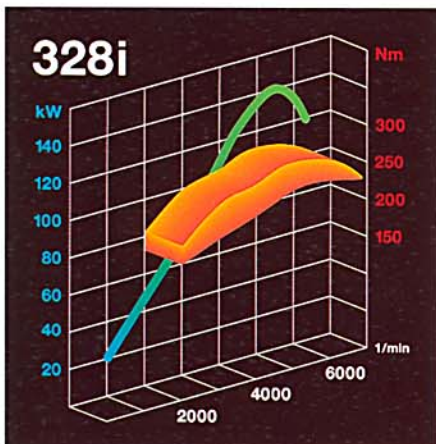
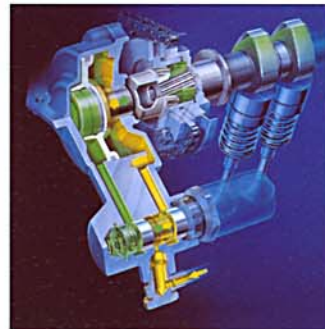

Silky smooth refinement and impressive performance: The 2.8-litre power unit develops an outstanding torque of

100 Nm or 74 lb-ft per litre. Performance and flexibility for relaxed but powerful cruising on surprisingly little fuel.

The torque curve provides an initial indication of the excellent performance the 318is has to offer.



With the precision of a computer, **Digital Motor Electronics (DME)** controls, monitors and masterminds all central functions such as the car's ignition and fuel injection, as well as numerous ancillary functions such as the oxygen sensor. As a result, DME guarantees optimum power and performance on minimum fuel and with enhanced emission control.

**On-board diagnosis** is one of the functions of Digital Motor Electronics. Its task is to recognise deficiencies at an early point in time before they can do any damage, defect reports therefore being electronically memorised and subsequently displayed on the screen of the BMW DIS Tester in the workshop. This facilitates the process of trouble-shooting and reduces the cost of maintenance to a minimum.

**Variable camshaft control (VANOS)** uses data provided by DME engine management to hydromechanically adjust the intake camshaft by 12.5° as a function of engine speed. The intake valves are therefore opened at a later point in time at low speeds in order to improve idling quality and refinement. At medium speeds, in turn, the intake valves are opened earlier, thus providing much more torque and recirculating exhaust emissions within the engine in the interest of enhanced fuel economy and emission control. At high engine speeds valve opening is once again retarded in the interest of maximum power.

**Four-valve technology** the spark plug in the centre of the combustion chamber ensures an even better cylinder charge for enhanced power and torque. Benefitting from two intake and outlet valves per cylinder, the engine is able to draw in more air and expel more exhaust gas in a shorter period. Another factor is that the particular arrangement of the four valves makes the design of the combustion chambers even more efficient, in this way helping to reduce fuel consumption.

The new 1.9-litre four-cylinder power unit of the 318is excels not only through its individual-control intake manifold (DISA) and a further increase in torque, but also through a wide range of improvements in technology. The roller-type rocker arms, for example, sub-

stantially reduce friction within the engine. The two-mass flywheel, in turn, enhances noise control, and designed injection valves ensure maximum power and performance on minimum fuel. The optimised exhaust system keeps emissions very low to protect the environment.

**Cylinder-specific knock control** gets the most out of the fuel consumed, ensuring that the engine always runs with maximum efficiency under all conditions.

maximum efficiency under all conditions and at all times.

**Digital Motor Electronics (DME)** controls all major functions of the engine and closed-loop catalytic converter, responding flexibly to all changes within the engine, such as fluctuations in temperature. The result is

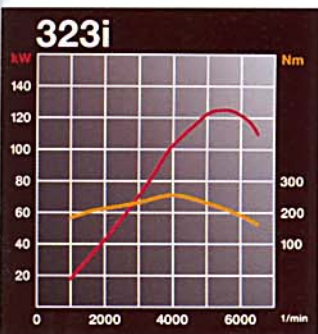
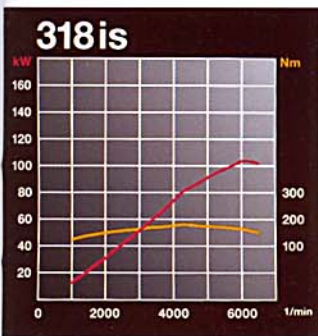

Classic straight-six design enhanced by future-oriented technology: The 2.5-litre power unit combines refinement and free-revving performance with optimum fuel economy and emission control.

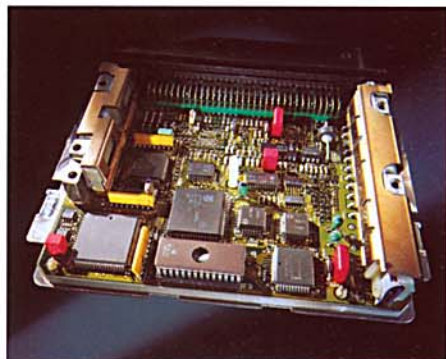
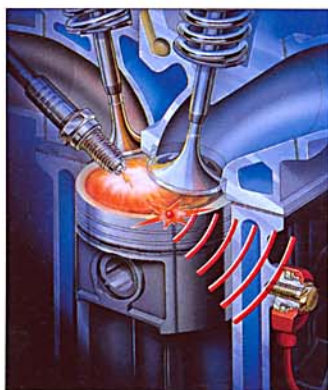

**Cylinder-specific knock control** offers maximum power and performance on minimum fuel. As soon as the engine is about to knock, sensors inform the DME control system accordingly, which immediately modifies the ignition angle and timing. As a result, the engine is able to run efficiently and without drawbacks on various levels of fuel quality.

The special feature about the **solid-state distributor system** is that each cylinder and each spark plug has its own separate coil, all units being controlled by DME. The result is even smoother combustion and greater fuel efficiency. A further advantage is that there are no moving – and therefore sensitive – parts, and that there are no wires or cables which may be destroyed or cut through.

Featuring **box-type pistons**, the weight of the 316i engine has been reduced even further than before. And apart from weight reduction, these pistons ensure greater smoothness and a lower level of engine noise.

The **individual-control intake manifold (DISA)** ensures a smooth torque curve throughout the entire speed range. At low engine speeds the long intake manifold boosts torque to a maximum. At high speeds a connection butterfly opens up between the manifolds to provide short intake travel for maximum power.

The **two-mass flywheel** ensures that the last, unavoidable unsmoothness in torque caused by the firing pulses cannot be conveyed by the engine via the clutch to the transmission. As a result, not even the slightest noise is able to reach the passenger compartment even at very low idling speeds.

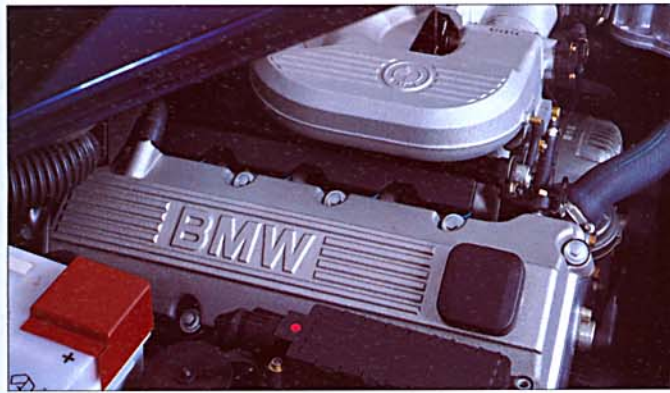

The highly economical four-cylinder displacing 1.6 litres. A free-revving, smooth and quiet engine combining superior power with equally superior efficiency. And an engine which,

thanks to the solid-state distributor system, hydraulic valve drive, and camshaft drive via a roller chain, reduces maintenance requirements to a minimum.

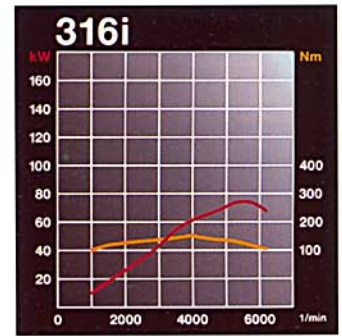

Agile and efficient, the four-cylinder revs freely and offers superior power at all speeds.

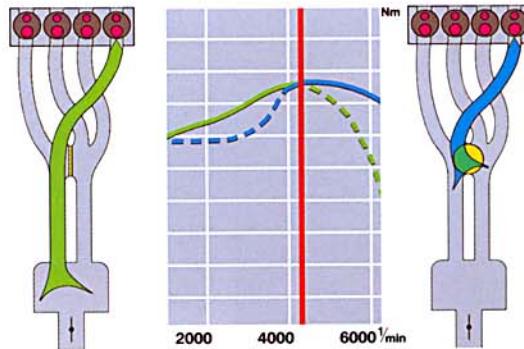

Benefiting from the individual-control intake manifold (DISA), the 318is and 316i offer superior torque and output throughout the entire engine speed range.

Valve drive improved to an even higher standard: Roller-type rocker arms significantly reduce friction on the camshaft,

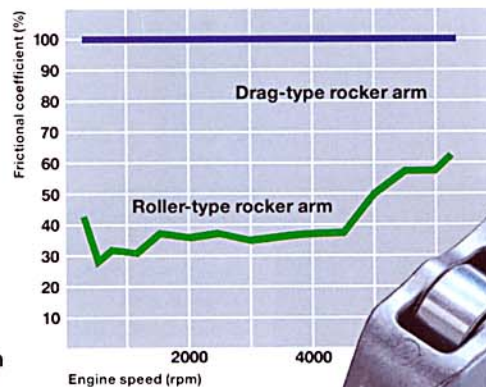

serving inter alia to enhance the engine's fuel efficiency.



Forming a winning team together with the spring strut front axle, the patented central arm rear axle provides the foundation for a thrilling experience on the road and excellent motoring comfort. The special alignment of the wheels ensures very good directional stability and cornering with impressive safety reserves – an essential prerequisite for active safety BMW-style.

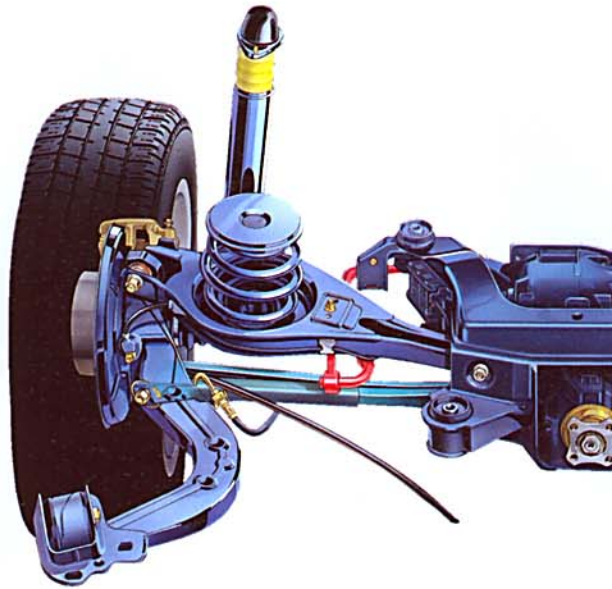

**BMW's F.I.R.S.T. (Fully Integrated Road Safety Technology) safety concept** combines all safety features to provide optimum results in every respect: active and passive safety, protection of other road users, and protection of the vehicle itself.

The **central arm rear axle** is an elaborately designed multi-link configuration saving both weight and space. It rests on two track control arms and one longitudinal arm pivoting on the central base in the body of the car. Precise interaction of these arms ensures that the wheels remain firmly on the road, regardless of spring motion. The result is excellent directional stability, the elastic steering mounts even giving the axle a specific steering effect and providing additional stability in bends. The mounts also absorb even the smallest vibrations caused by bumps on the road and give the car excellent roll comfort and acoustic control.



**BMW long-term quality** is the result, inter alia, of a consistent, up-to-date quality concept. Electrolytically hot-galvanised body panels, an all-round rustproofing system featuring phosphate coating and a cathodic dip bath, as well as plastic coating, underfloor and hollow cavity preservation help to ensure your driving pleasure for a long, long time. A further point is that BMW's particular production process and the large share of recyclable materials help to save resources: More than 80 per cent of all the parts and components on BMW's more recent models can be recycled, and the BMW 3 Series comes with more than 50 components made of recycled plastics.

The BMW 3 Series sets the standard in its class through its outstanding chassis and suspension combining a firm ride with superior comfort, agility

with safe handling. And the well-balanced combination of track versus wheelbase as well as front-to-rear weight distribution of almost

50:50 ensure an excellent blend of maximum safety and supreme comfort. The result is neutral, forgiving handling and thrilling agility on the road.

**The electronic/hydraulic (EH) automatic transmission** conveys power hydraulically from the engine to the gearbox. Gears are selected automatically according to your specific driving situation. And you have the option to choose between an economic (E) and a sporting (S) style of motoring. With its active layout, the five-speed automatic transmission changes back to a lower gear whenever necessary even at high speeds, thus offering powerful acceleration when needed, while 5th gear provides an economy or overdrive function. You also have a special winter driving program (\*) enabling you to start off sensitively on slippery surfaces by keeping gearshifts particularly soft and smooth. The same function is provided by the four-speed automatic transmission on the 316i and 318is, where program M retains the gear selected in position, enabling you, for example, to start off in 3rd gear on snow and slush.

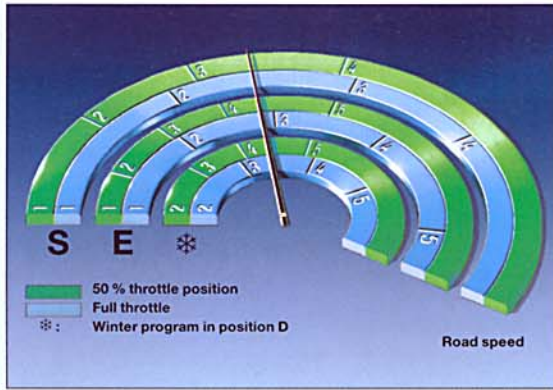

**Modern comfort:** The five-speed EH automatic transmission available for the 328i and 323i features no less than three different driving programs. As a result, you can choose either a

sporting or more economic style of motoring, a further option being the winter program enabling you to set off particularly smoothly without the wheels spinning.

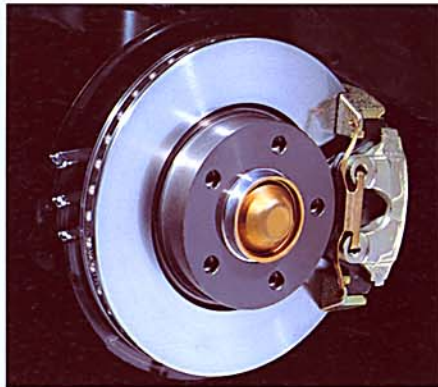

**Asbestos-free brakes with extra-large brake discs** guarantee excellent stopping power.

**BMW's restraint system features** a belt latch tensioner tightening the belt significantly in the event of a collision: The belt latch is pulled back within fractions of a second, the shoulder and lap belts are tightened simultaneously. The submarining protection, in turn, is a ramp-shaped unit at the front end of the seat. Adding to the effect of the belt latch tensioner, it makes sure that the driver and front passenger cannot dive beneath the lap belt in the event of an impact.

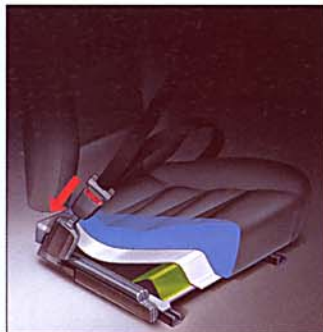

**The BMW restraint system: acting together with maximum efficiency, the seat belt, belt latch tensioner, and submarining**

protection keep you safely in your seat in the event of a collision.

With **the ergonomic belt system at the rear featuring belt latches at the outside**, the belts come out of the parcel shelf at right angles to provide almost ideal belt geometry. The lap belt is also positioned more efficiently in the interest of improved restraint, the entire concept ensuring in this way that passengers at the rear cannot hit each other in a side-on collision. A further advantage is that you can conveniently fasten the seat belt with only one hand.

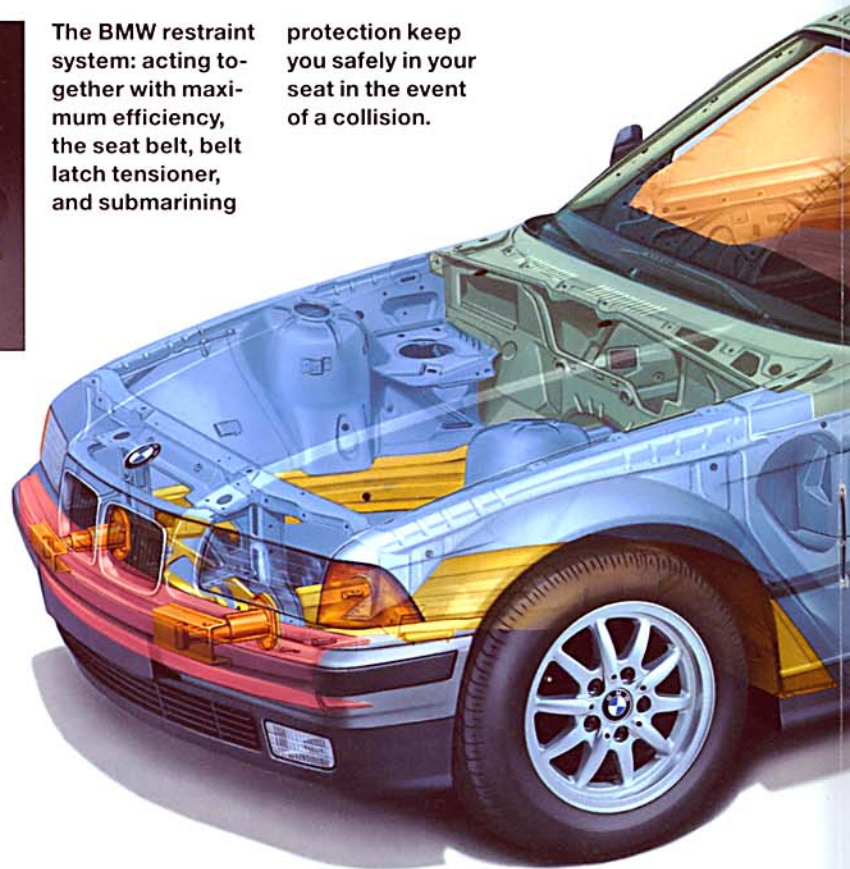



To ensure extra safety and comfort on the road, the extremely stable bodyshell of the 3 Series coupé which has high levels of both torsional and flexural rigidity is tested on special test rigs.

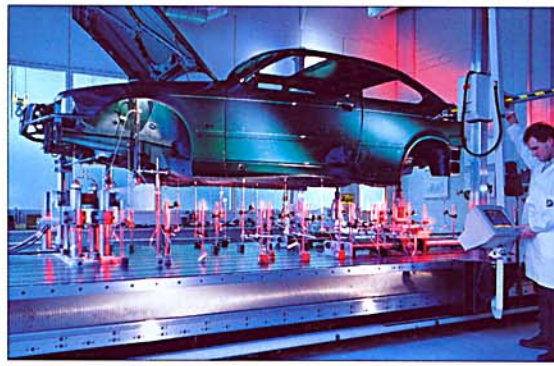

## Technology Guide

The **ABS anti-lock brake system** prevents the wheels from locking when applying the brakes, thus offering optimum stopping power, and keeping the car easy to control even when braking hard. Each wheel is equipped with a speed sensor connected to the ABS control unit. The speed at which each wheel is rotating is constantly compared and is matched with the speed at which the car is trav-

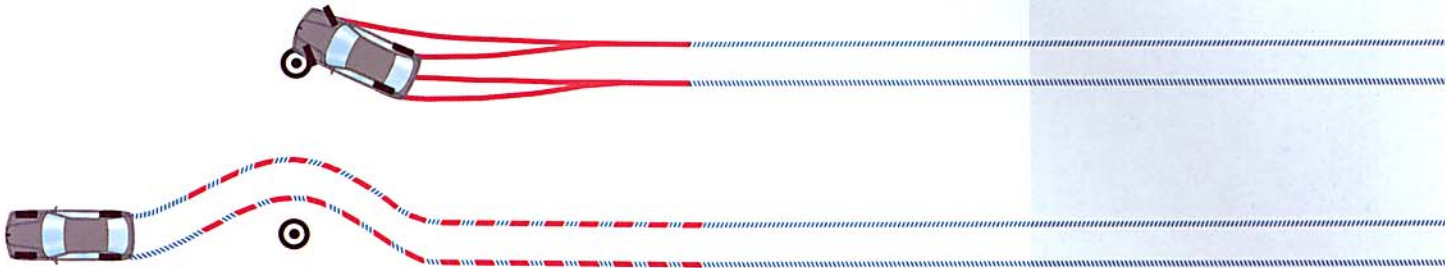

The highly sophisticated ABS anti-lock brake system provides out-

standing reserves in critical situations, thus keeping you in full con-

trol of your car even when applying the brakes in a panic situation.

elling. As soon as the speed at which a wheel is running drops significantly, the hydraulic system recognises the risk of the wheels locking and immediately reduces pressure in the hydraulic brake line.

The outstanding **torsional and flexural rigidity** of the bodyshell is one of the essential prerequisites for the supreme safety and motoring comfort offered by the BMW 3 Series coupé. Extra-large supports and reinforced junction points help to enhance the above-average protection ensured by the extremely stable passenger compartment. This high standard of static and dynamic stability also provides the foundation for the exactly calculated kinematic behaviour of the central arm rear axle. And in addition, the stable bodyshell largely eliminates any potentially disturbing noise, offering you supreme peace and quiet at all times.

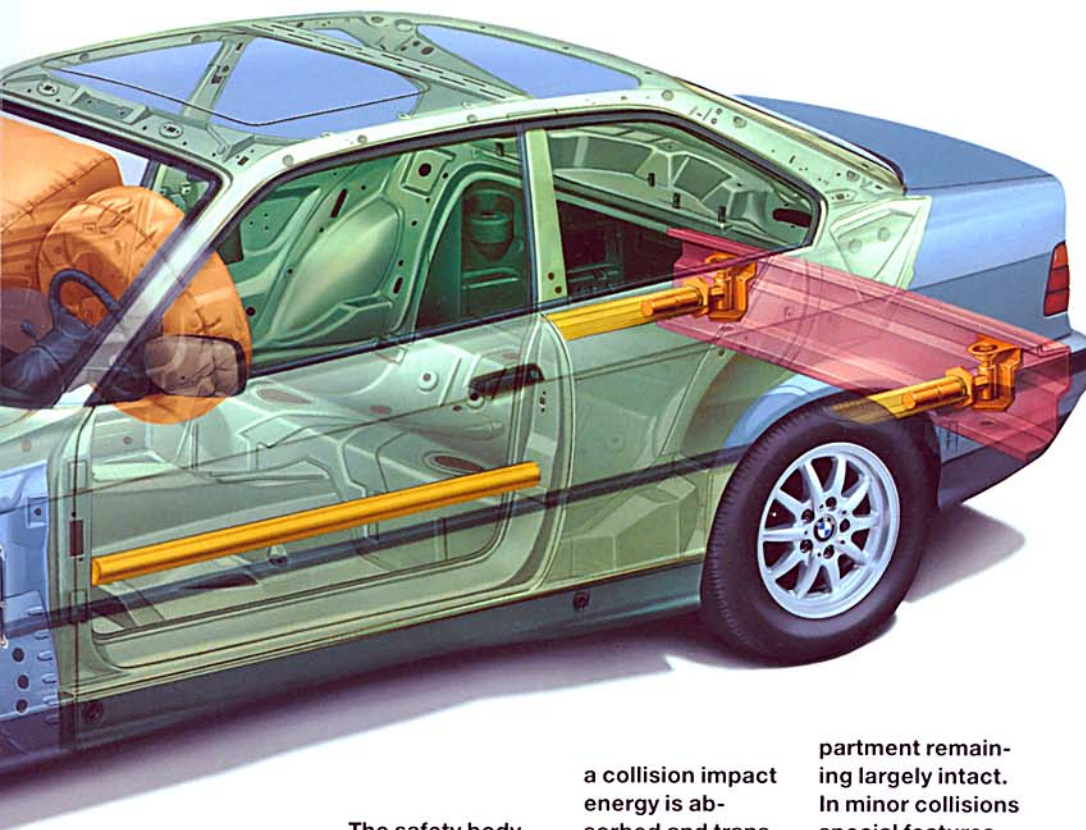

The safety bodyshell with integral side impact protectors ensures the very best in passive safety. In

a collision impact energy is absorbed and transmitted by specially designed crumple units, the extremely stable passenger com-

partment remaining largely intact. In minor collisions special features such as the regenerating impact absorbers keep damage to an absolute minimum.

Reversible impact absorbers and crumple units serve to **protect the car itself**. Impact energy is absorbed in full in collisions up to 4 km/h or 2.5 mph, while in collisions up to 15 km/h or 9 mph damage is limited to the easily exchangeable crumple units, keeping the cost of repair to a minimum.

**Supreme ergonomics, superior comfort and genuine freedom of space get you to your destination relaxed and in style. On the way you will enjoy an interior offering consistent quality throughout. Because we are convinced that good balance is the most important requirement for genuine driving pleasure.**

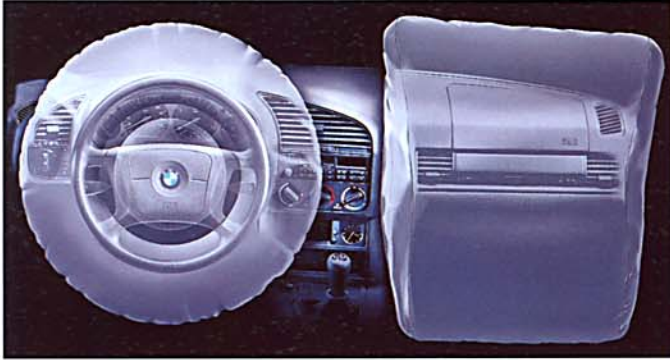

Just in case: the airbag fitted as standard for the driver and as an option for the front passenger to give you optimum protection in a frontal collision.

Whenever an airbag is fitted on the passenger side, make sure that the guidelines for use contained in the owners handbook are strictly adhered to. And to guarantee that the passenger airbag is only activated

when really necessary, the seat comes with a special occupation detector avoiding any unnecessary cost of repair.

Top quality proven on long distances for years on end: The sports seats available as an option have greater body contour offering excellent side support. The side panels on the outside of the seat bottom and backrest wrap around your body, without in any way limiting your freedom of movement. In addition, you can adjust the seats for angle and vary the length of the thigh support.



The very comfortable standard seats in shell design and multi-zone foam technology are made in accordance with the latest orthopaedic findings. Upholstered firmly but pleasantly, they offer very good support at the side and for your legs. And the angle of the seats may be adjusted as standard for both the driver and front passenger.



Absolutely clear in every respect: The classic circular dials present important data with optimum clarity. And additional in-

formation is provided by unmistakable symbols and digital displays.



The cockpit in BMW's typical arched design, ensuring that all instruments and controls are exactly where they

should be. The Multi-Information Display clearly presenting information from the Check/Control or the on-board computer. Comfort is provided in the 3

Series coupé by the electronically controlled heating system, electric window lift and practical through-loading.

At speeds over 20 km/h or 12 mph, **Energy Control** constantly informs you of your current fuel consumption, in this way improving your fuel efficiency. The analogue-face display is integrated in the rev counter.

**Check/Control** monitors all major functions of the vehicle, informing the driver of their condition and any deviation from target requirements. Important bulbs and lights are also monitored, even when switched off. The message received is presented in clear language by the Multi-Information Display (MID) and is supported by a sound signal, information being categorised in three priority levels as a function of significance.

The **electronic immobiliser** safeguards your car with unique efficiency: The ignition key comprises an electronically coded chip based on your own, permanent personal code and a second code modified by the electronic immobiliser every time the engine is started. Immediately when switching on the ignition, this "intelligent" system first reads your personal code and then checks the individual code varied each time. If both responses are accepted, the immobiliser transfers a coded signal actuating the Digital Motor Electronics (DME). Without this signal the engine cannot be started, not even by short-circuiting. The energy required for exchanging data in the manner described is conveyed by an aerial in the steering wheel lock, ie, through an entirely wireless connection. The same transmission system is used on keys with remote control. Should the battery of a remote control key run flat, you can obviously still unlock the doors of your car and start the engine. If, finally, you one day lose your key, you can have it cancelled by your authorised BMW dealer.



Waiting for your command: Featuring a new electronic immobiliser, the engine of your BMW will start

only after the control unit has verified the code on the key of your car.

The ability to proudly present your own personal style is a fundamental aspect of our philosophy. Which is why the BMW Personal Line equipment concept allows you to create your BMW 3 Series coupé according to your own personal taste, choosing from an exceptional range of powerful colours and top-quality materials.



Standard seats in Anthracite wool velour.

Sports seats in Classic Red cloth and leather combination.



In creating the interior of your car, you can choose not only the colour, but also the material and type of seat. The standard seats are available in flat weave and –

at no extra cost – in top-quality wool velour. And leather seats are available as an option. The sports seats fitted as special equipment come in flat weave, leather, and a combination of leather and fabric.





**A world of colour:** You can choose from 14 different paintwork colours and up to 9 interior colours. Either colour-matched with the exterior colour or forming an interesting contrast.

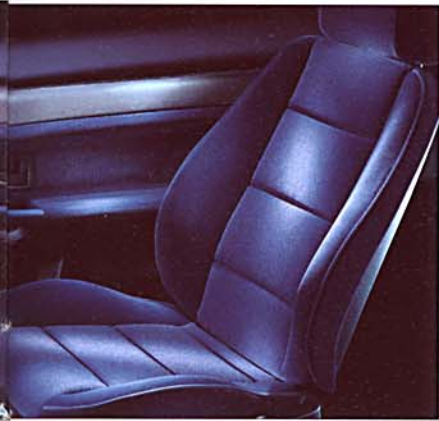

**Standard seats in Violet Blue wool velour.**



**Sports seats in Turquoise fabric and leather combined.**

**Standard seats in Saffron Yellow leather.**



**Supreme performance** is a matter of principle in the BMW world. For example when combining the qualities of a sportscar with everyday reliability. Or creating a synthesis of outstanding power and smooth refinement. All this with a standard of fuel economy never seen before in this class. This is how we transfer our experience from the race track to the road.



The new 3.2-litre high-performance power unit develops more than 100 bhp per litre. Maximum torque of 350 Nm comes

at an extremely low 3250 rpm, emissions and fuel economy have been reduced even further.



One of the most thrilling normally aspirated engines of our times, a six-speed manual gearbox, brakes adopted straight

from motorsport, and a high-performance suspension system which ensures superior motoring refinement at all times.



All the features of a sports car come as standard in the M3 Coupé, for example the newly developed high performance floating brakes on the front wheels and specially contoured sports seats.



**Versatility** is one of the most outstanding features of the BMW 3 Series – whether in Saloon, Coupé, Convertible or Touring guise. It is reflected not only by numerous model variants, but also by the wide range of special equipment. So that you can make all your personal wishes come true – in true BMW-style.

BMW's 7 J x 15 light alloy wheels in sports-spoke styling II with 205/60 R 15 low-profile tyres.



BMW's 7 J x 15 light alloy wheels in cross-spoke styling with 225/55 R 15 low-profile tyres. (Not available for 328i.)



BMW's 7 J x 16 light alloy wheels in double-spoke styling with 225/50 R 16 low-profile tyres.



Available in a range of colours, the 3 Series Coupés can be

specified with bumpers and side sill panels fully painted in the car's

colour (please consult your BMW dealer for colour availability).

BMW's 7 J x 16 light alloy wheels in classic styling with 225/50 R 16 low-profile tyres.





**BMW Service.** The technical qualities and high standards we apply to our cars are also applied to the aftersales services we offer our customers.

In the area of service, our primary objective is first-class, personalised customer care. We want our customers to keep returning to buy BMW cars, and we recognise that only complete satisfaction, throughout ownership, will ensure this.

Reliable and economical service begins with the development of BMW cars. Design concepts incorporate easy repair, while sophisticated technical systems, such as the BMW Service Interval Indicator and On-Board Di-

scheduling of services to match how the car has been driven and rapid and accurate diagnosis of faults.

These systems are backed by a Dealer Network dedicated to delivering customer satisfaction. Their investment in technicians trained by BMW to BMW standards, and the most advanced equipment, designed by BMW for exclusive use on our cars, ensures you receive exemplary technical service. Their use of BMW Approved Parts also ensures cost effective servicing

and repair to the highest levels of accuracy and reliability to maintain your car to its original design qualities.

Finally, for complete peace of mind, this is all backed by the 3 Year BMW Dealer Warranty incorporating the BMW Emergency Service. The BMW Service Card represents your entitlement to this service, which in case of emergency, provides attendance and recovery throughout Europe, to get you and your car back home, or to your final destination.



**BMW Finance (GB) Limited** offers a range of financing options to suit the needs of BMW customers. Each package can be tailored to satisfy your particular requirements, whether it is for you as an individual or your business. BMW Finance will allow you to drive the BMW you choose at a budget you can afford.



No one gets you closer to the BMW you want than BMW Finance. Dedicated to the BMW motorist, BMW Finance offers a complete portfolio of finance facilities for the discerning BMW driver – for your own use or your business. The finance facility you choose can be matched to suit both your budget and your current and future motor-

ing requirements. BMW Finance also offers the option of budgeting your maintenance costs via BMW Contract Maintenance. Our range includes insurance, designed to the highest BMW standards, for carefree motoring and genuine peace of mind. The BMW Finance and Insurance facilities include:

- \* Hire Purchase
- \* Lease Purchase

- \* Select Leasing
- \* Contract Hire
- \* Guaranteed Payment Plan
- \* Shortfall Insurance
- \* BMW Insurance

If you require further information or details on any of the above finance facilities, contact either your local BMW dealer, or BMW Finance at the following address:

**BMW Finance (GB) Ltd**

Ellesfield Avenue  
Bracknell  
Berkshire  
RG12 8TA  
Written quotations are available on request from your local dealer. Indemnities may be required.

# Standard equipment.

	316i	318is	323i	328i	328i Sport
<b>Safety</b>					
Anti-lock brake system (ABS)	●	●	●	●	●
Asbestos-free clutch and brake linings	●	●	●	●	●
Brakes:					
– Disc brakes at the front, drum brakes at the rear	●	○	○	○	○
– Disc brakes at the front, inner-vented	○	●	●	●	●
– Disc brakes at the rear	○	●	●	●	●
Bumpers front/rear regenerating fully to their original shape in impacts up to 4 km/h or 2.5 mph	●	●	●	●	●
Central locking with electronic immobiliser, crash sensor; fuel tank filler flap integrated in central locking, master key with micro-torch, side windows with comfort opening and closing function	●	●	●	●	●
Driver airbag – with leather sports steering wheel	●	●	●	●	●
Ergonomic belt system at the rear	●	●	●	●	●
Inertia-reel seat belts at the front with belt latch tensioner and belt retainer	●	●	●	●	●
Integral side impact protectors and roof crossbar	●	●	●	●	●
Manual adjustment of seat belt height on B-pillar	●	●	●	●	●
Parking protection provided by wrap-around plastic bumpers and side strips	●	●	●	●	●
Power steering with safety steering column	●	●	●	●	●
Predetermined crumple zones front and rear	●	●	●	●	●
<b>Engine</b>					
Closed-loop catalytic converter, heated oxygen sensor, activated carbon filter, controlled tank purge	●	●	●	●	●
Cylinder-specific knock control	●	●	●	●	●
Digital Motor Electronics (DME)	●	●	●	●	●
Four-valve technology	○	●	●	●	●
Hydraulic valve play compensation	●	●	●	●	●
Individual-control intake manifold (DISA)	●	●	○	○	○
Light-alloy cylinder head	●	●	●	●	●
On-board diagnosis	●	●	●	●	●
Solid-state distributor system	●	●	●	●	●
Straight-four cylinder engine	●	●	○	○	○
Straight-six cylinder engine	○	○	●	●	●
Valve drive with roller-type rocker arms	●	●	○	○	○
Variable camshaft control (VANOS)	○	○	●	●	●
<b>Transmission/suspension</b>					
BMW "M" tuned sports suspension	○	○	○	○	●
Central arm rear axle with anti-squat, anti-dive and anti-roll bar	●	●	●	●	●
Five-speed manual gearbox with direct transmission in fifth gear	●	●	●	●	●
Limited slip differential	△	△	△	△	●
Sports suspension BMW M	●	●	●	●	○
Spring strut front axle with anti-dive and anti-roll bar	●	●	●	●	●
Two-mass flywheel (on manual gearbox models)	○	●	●	●	●
<b>Exterior features</b>					
Aerodynamic bodykit "M" design including front and rear lower spoilers and side skirts	○	○	○	○	●
All-round rustproofing system with hot-galvanising, phosphate coating and cathodic dip bath, preservation of hollow cavities, underfloor protection	●	●	●	●	●
Bumpers in body colour at the top, contrasting colour at the bottom	●	●	●	●	●
Electrically adjustable rear-view mirrors	●	●	●	●	●
Engine compartment lid and luggage compartment lid supported by gas-pressure springs	●	●	●	●	●
Foglamps in free-form technology	△	△	●	●	●
Frameless side windows	●	●	●	●	●
Green heat-insulating glass all round with laminated windscreen	●	●	●	●	●
High level third brakelight	●	●	●	●	●
Luggage compartment loading sill extending down to bumper level	●	●	●	●	●
Plastic fuel tank, capacity approx 62 ltr	●	●	●	●	●
Rear-view mirrors and grab handle on luggage compartment lid in body colour	●	●	●	●	●
Wheel arches at the front with plastic inserts	●	●	●	●	●
Wheels: light alloy in cross-spoke "M" design – 235/40 R 17 tyres	○	○	○	○	●
Wheels: light alloy in sports-spoke II styling – 205/60 R 15 tyres	●	●	●	●	○
<b>Interior features</b>					
Analogue-face clock in the centre console	●	●	●	○	○
Analogue-face instruments with anti-dazzle illumination	●	●	●	●	●

● Standard ○ Not available on this model △ Cost optional

	316i	318is	323i	328i	328i Sport
Armrests on the doors with integral closing handles	●	●	●	●	●
Automatic operation of courtesy lights with soft on/off dimming	●	●	●	●	●
Automatically dimming interior rear view mirror	●	●	●	●	●
Black headlining	○	○	○	○	●
BMW tools in a special tray in the luggage compartment lid	●	●	●	●	●
Cloth/leather upholstery	△	△	△	△	●
Digital clock	△	△	△	●	●
Door cutouts with aluminium embellishment strips	○	○	○	●	●
Electrically adjustable headlight range control	●	●	●	●	●
Electric window lifts at the front, with fingertip control and trap release	●	●	●	●	●
Electronically controlled heating system independent of road speed, multi-stage radial blower	●	●	●	●	●
Front seats automatically moving to the front when tilted forwards, front passenger backrest may be unlocked and tilted forwards from driver's seat	●	●	●	●	●
Fully reclining front seats with fine backrest adjustment, fore-and-aft seat adjustment, driver's and front passenger's seats adjustable for height	●	●	●	●	●
Gearshift lever gaiter, handbrake handle and gaiter all finished in leather	○	○	○	●	●
Headrests at the front, adjustable for height and angle	●	●	●	●	●
Interior carpeting in velour, driver's footrest integrated inside panel	●	●	●	●	●
Interior light package – including map, sun visor and ashtray lights	●	●	●	●	●
LIGHTS ON? warning	●	●	●	●	●
Lockable, illuminated glove compartment	●	●	●	●	●
Luggage compartment capacity 405 ltr (14.2 cu ft) (to VDA standard)	●	●	●	●	●
Luggage compartment with fabric lining all round	●	●	●	●	●
Multi-Information Display with Check/Control and alphanumeric display	○	○	△	●	●
Rear seats with individual body contour	●	●	●	●	●
Rev counter with Energy Control, fuel gauge, coolant thermometer, LC display for mileage and trip counter	●	●	●	●	●
Service Interval Indicator	●	●	●	●	●
Side windows at the front automatically moving down and up by approx 12 mm when opening and closing doors	●	●	●	●	●
Spare wheel beneath the floor inside the luggage compartment	●	●	●	●	●
Sports seats	△	△	△	△	●
Steering column adjustment, manual	●	●	●	●	●
Steering wheel rim and gearshift lever knob in leather	●	●	●	●	●
Storage space in the centre console, tunnel console, in storage boxes on the front doors; additional storage space on cars featuring the non-smoker package	●	●	●	●	●
Stowage points in luggage compartment	●	●	●	●	●
Through-loading system, rear seats tilting forwards with 50:50 subdivision	●	●	●	●	●
Twin-tone horn	●	●	●	●	●
Vanity mirror for driver (with slide cover) and front passenger	●	●	●	●	●
Warning triangle and first-aid kit in a separate box at the right-hand side of the luggage compartment	●	●	●	●	●

● Standard ○ Not available on this model △ Cost optional

The models illustrated in this brochure show the specifications for the U. K. In part, they include optional equipment and accessories not fitted as standard. According to the specific requirements of other markets, alterations in models, standard and optional equipment, as described in the text and illustrations, may occur. For precise information, please contact your BMW dealer. Subject to change in design and equipment.

© BMW AG, Munich/Germany. Not to be reproduced wholly or in part without written permission of BMW AG, Munich.

# Specifications.

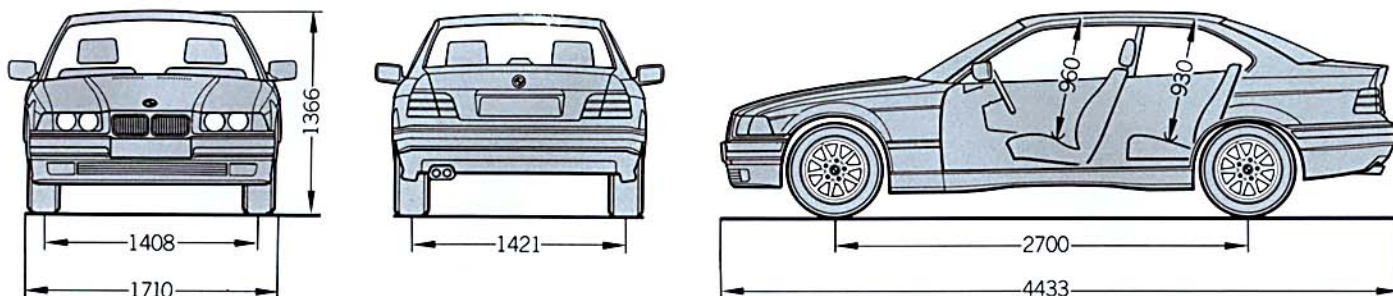

Figures apply to millimetres. Figures do not apply to the M3 Coupé.

Weight		316i	318is	323i	328i (Sport)	M3 <sup>1)</sup>
Unladen <sup>2)</sup>	kg	1310 (1350)	1335 (1375)	1385 [1420]	1395 [1430]	1515
Max permissible	kg	1695 (1735)	1720 (1760)	1770 [1805]	1780 [1815]	1930
Permitted load	kg	460	460	460	460	490
Permitted axle load front/rear	kg	810/995	825/1005	845/1040	855/1040	910/1120
Permitted roof load	kg	75	75	75	75	75
Permitted trailer load, unbraked	kg	630	650	670	670	-

Engine <sup>3)</sup>		316i	318is	323i	328i (Sport)	M3 <sup>1)</sup>
Cylinders/valves		4/2	4/4	6/4	6/4	6/4
Capacity	cc	1596	1895	2494	2793	3201
Stroke/bore	mm	72.0/84.0	83.5/85.0	75.0/84.0	84.0/84.0	91.0/86.4
Max output	kW/bhp/rpm	75/102/5500	103/140/6000	125/170/5500	142/193/5300	236/321/7400
Max torque	Nm/rpm	150/3900	180/4300	245/3950	280/3950	350/3250
Compression ratio	:1	9.7	10.0	10.5	10.2	11.3

Transmission		316i	318is	323i	328i (Sport)	M3 <sup>1)</sup>
Standard gearbox ratios I/II/III	:1	4.23/2.52/1.66	4.23/2.52/1.66	4.23/2.52/1.66	4.20/2.49/1.66	4.23/2.51/1.67
	IV/V/VI/R	1.22/1.00/-/4.04	1.22/1.00/-/4.04	1.22/1.00/-/4.04	1.24/1.00/-/3.89	1.23/1.00/0.83/3.75
Final drive ratio	:1	3.38 (4.44)	3.38 (4.44)	2.93 [2.93]	2.93 [3.07]	3.23

Performance		316i	318is	323i	328i (Sport)	M3 <sup>1)</sup>
Drag coefficient	c <sub>d</sub>	0.29	0.30	0.30	0.30	0.32
Top speed	km/mph	195 (192)/121 (119)	213 (207)/132 (129)	227 [224]/140 [139]	236 [232]/146 [144]	250/155 <sup>4)</sup>
Acceleration 0-100 km/h (62 mph)	sec	12.7 (14.2)	10.2 (11.2)	8.0 [9.0]	7.3 [7.8]	5.5
standing-start km	sec	33.8 (35.3)	31.1 (32.7)	28.9 [29.9]	28.0 [28.5]	24.7
Flexibility 80-120 km/h in 4th gear						
(standard gearbox)	sec	12.2	10.7	9.1	7.6	5.7

Fuel consumption <sup>3) 5)</sup>		316i	318is	323i	328i (Sport)	M3 <sup>1)</sup>
Urban (cold)	ltr/100 km/mpg	10.6 (11.8)/26.6 (23.9)	11.4 (12.8)/24.8 (22.1)	12.9 [15.0]/21.9 [18.8]	13.5 [15.3]/20.9 [18.5]	16.9/16.7
Extra urban	ltr/100 km/mpg	5.9 (6.4)/47.9 (44.1)	6.1 (6.5)/46.3 (43.5)	6.7 [7.3]/42.2 [38.7]	6.7 [7.3]/42.2 [38.7]	7.5/37.7
Combined	ltr/100 km/mpg	7.7 (8.4)/36.7 (33.6)	8.0 (8.8)/35.3 (32.1)	9.0 [10.1]/31.4 [28.0]	9.2 [10.2]/30.7 [27.7]	11.0/25.7
CO <sub>2</sub> emissions	g/km	182 (199)	190 (209)	213 [240]	218 [243]	275
Tank capacity, approx	ltr	62	62	62	62	62

Wheels		316i	318is	323i	328i (Sport)	M3 <sup>1)</sup>
Tyre dimensions		205/60 R 15	205/60 R 15	205/60 R 15	205/60 R 15 (235/40 R 17) <sup>6)</sup>	225/45 R 17 front 245/40 R 17 rear
Rim dimensions		7 J x 15	7 J x 15	7 J x 15	7 J x 15 (7 1/2 J x 17) <sup>6)</sup>	7 1/2 J x 17 front 8 1/2 J x 17 rear
Material		Light alloy	Light alloy	Light alloy	Light alloy	Light alloy

Electrical system		316i	318is	323i	328i (Sport)	M3 <sup>1)</sup>
Battery capacity	Ah	50	50	65	65	65
Alternator output	A/W	70 (80)/980 (1120)	70 (80)/980 (1120)	80/1120	80/1120	115/1610

<sup>1)</sup> For more details on the M3 Coupé, see the new M3 models brochure.

<sup>2)</sup> According to the EC standard, the figure quoted includes 68 kg for the driver and 7 kg for luggage. Unladen weight applies to vehicles in standard trim. Special equipment may increase this figure.

<sup>3)</sup> Engines with knock control are designed for RON 95 fuel. Use of RON 98 fuel reduces consumption under normal conditions and increases power accordingly.

<sup>4)</sup> Electronically limited.

<sup>5)</sup> Figures apply to directive 93/116/EC.

<sup>6)</sup> 328i Sport.

Figures in ( ) apply to vehicles with 4-speed automatic transmission.

Figures in [ ] apply to vehicles with 5-speed automatic transmission.

# Special equipment.













	316i	318is	323i	328i	328i Sport
Airbag for front passenger	△	△	△	△	△
Anti-theft warning system with remote control	△	△	△	△	△
Automatic air conditioning with microfilter	△	△	△	△	△
Automatic air recirculation – only with air conditioning	△	△	△	△	△
Automatic speed hold	△	△	△	△	△
Automatic Stability Control + Traction (ASC + T) (not with LSD)	○	○	○	△	△
Automatic transmission:					
– Four-speed EH automatic	△	△	○	○	○
– Five-speed EH automatic	○	○	△	△	△
Check/Control	○	○	△	●	●
Clock & outside temperature display	△	△	△	△	△
Driver's and front passenger's seats electrically heated	△	△	△	△	△
Electric front-seat adjustment	△	△	△	△	△
Front centre armrest available in Black, Dark Grey, Dark Beige depending on interior colour	△	△	△	△	△
Front foglamps	△	△	●	●	●
Full colour bumpers in body colour including side skirts	△	△	△	△	●
Graduated tinted windscreen	△	△	△	△	△
Headlamp wash system	△	△	△	△	△
Heated mirrors, driver's door lock and washer nozzles	△	△	△	△	△
HiFi loudspeaker system – excluding radio cassette/CD player	△	△	△	△	△
Increased power supply	△	△	△	△	△
Leather upholstery: cloth/leather combination (only with sports seats)	△	△	△	△	●
Leather upholstery: Montana	△	△	△	△	△
Limited-slip differential 25 % locking action (not with ASC + T)	△	△	△	△	●
Lumbar support for front seats (not with sports seats)	△	△	△	△	○
Metallic paintwork	△	△	△	△	△
No model inscription	NC	NC	NC	NC	NC
Non-smoker package	NC	NC	NC	NC	NC
On-board computer V incl. auxiliary ventilation	△	△	△	△	△
Park Distance Control (PDC), rear only (not with towbar)	△	△	△	△	△
Rear headrest, manual	△	△	●	●	●
Rear window blind, manual	△	△	△	△	△
Sliding/vent roof, power-operated	△	△	△	△	△
Sports seats	△	△	△	△	●
Standard suspension	NC	NC	NC	NC	○
Towbar with removable ball joint (not with PDC)	△	△	△	△	○
Wheels: light alloy in classic styling – 225/50 R 16 tyres	△	△	△	△	○
Wheels: light alloy in cross-spoke styling – 225/55 R 15 tyres	△	△	△	○	○
Wheels: light alloy in double-spoke styling – 225/50 R 16 tyres	△	△	△	△	○

● Standard ○ Not available on this model △ Cost optional NC No cost

All of the options listed above are available factory fitted. To meet any further requests you might have, we offer a wide range of BMW accessories developed by BMW and in BMW quality. Both these accessories as such and their installation are covered by our standard warranty. For further information, please contact your BMW dealer, who can offer you helpful advice and a special accessories brochure.

# Exterior and interior colours.

- Recommended.
- Available.

Exterior colours	Interior colours	Cloth					Cloth/leather combined <sup>1)</sup>			Leather <sup>1)</sup>					
		Anthracite	Grey	Classic Red	Turquoise	Violet Blue	Anthracite	Classic Red	Turquoise	Black	Light Grey	Beige	Classic Red	Violet Blue	Saffron Yellow
Non-metallic															
	300 Alpine White	●		●	○	●	●	●	○	●		○	●	●	
	314 Bright Red	●					●			●					
	668 Jet Black	●	●	●	●	●	●	●	●	●	●	●	●	●	●
	263 Dark Blue		●								●				
Metallic <sup>1)</sup>															
	309 Arctic Silver	●	●	●	○	●	●	●	○	●	●		●	●	○
	269 Arctic Grey	●	●	●	○		●	●	○	●	●		●		○
	295 Samoa Blue	●				●	●			●				●	
	288 Morea Green	●	○		●		●		●	●					
	252 Calypso Red	●	○	●			●	●		●	○	○	●		
	297 Montreal Blue	●	●			○	●			●	●	○		○	○
	275 Boston Green	●					●			●		○			
	286 Cordoba Red	●	●				●			●	●	○			
	302 Madeira Violet	●	○			●	●			●	○			●	
	303 Cosmos Black	●	●	●	●	●	●	●	●	●	●	●	●	●	●

Experience shows that it is impossible to properly render the exact colour of the paintwork and upholstery on paper. We therefore advise you to inspect the original colours at your BMW dealership. Your BMW dealer will be glad to help.

<sup>1)</sup> Optional.

# Materials.

Type of seat	Standard	Optional				
	Standard seat	Sports seat	Standard seat	Sports seat	Standard seat	Sports seat
<b>Material</b>	Cloth flat weave (woven fabric) 	Cloth wool velour 	Cloth/leather combined 	Leather Montana 	Leather Montana 	
<b>Interior colours</b>						
Anthracite 	D6AT	C4AT	C1AT			
Grey 	D6TT	C4TT				
Beige 				P8SN	P7SN	
Classic Red 	D6GD		C1GD		P7GD	
Turquoise 	D6TK		C1TK			
Violet Blue 		C4MA		P8MA	P7MA	
Saffron Yellow 				P8SG	P7SG	
Light Grey 				P8TH	P7TH	
Black 				P8SW	P7SW	

**BMW – the ultimate driving machine.**